

March 2020

# Types 627W and 627WH Direct-Operated Pressure Reducing Liquid Regulators

## WARNING

Fisher™ regulators must be installed, operated, and maintained in accordance with federal, state, and local codes, rules and regulations, and manufacturer's instructions.

Installation, operation, and maintenance procedures performed by unqualified personnel may result in improper adjustment and unsafe operation. Either condition may result in equipment damage or personal injury. Use qualified personnel when installing, operating, and maintaining the Types 627W and 627WH regulators.

## Introduction

### Scope of the Manual

This Instruction Manual provides installation, startup, adjustment, maintenance, and parts ordering information for the Types 627W and 627WH pressure reducing regulators for liquid service. Only personnel qualified through training or experience should install, operate, and maintain these regulators. If there are any questions concerning these instructions, contact your local Sales Office before proceeding.

### Description

The Types 627W and 627WH (Figure 1) are direct-operated pressure reducing regulators for liquid service. On the internal registration version, downstream pressure is registered internally through the body to the underside of the diaphragm.

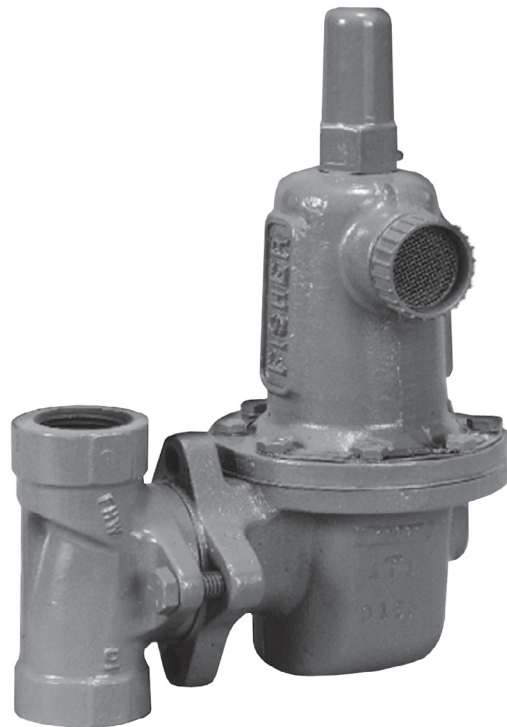

W4793

**Figure 1.** Types 627W and 627WH Pressure Reducing Liquid Regulator

Types 627W and 627WH direct-operated regulators are also available in a downstream control line version for external pressure registration. The control line version has a blocked throat with an O-ring stem seal and a 1/4 NPT control line connection in the diaphragm case. The stem seal separates the body outlet pressure from the diaphragm case.

# Types 627W and 627WH

## Specifications

Refer to Specifications lists for Types 627W and 627WH constructions on page 2. Specifications for a given regulator as it originally comes from the factory are stamped on the spring case nameplate.

<p><b>Available Construction</b>  <b>Type 627W:</b> Direct-operated pressure reducing liquid regulator (Figure 2)  <b>Type 627WH:</b> Type 627W with a diaphragm limiter to deliver a higher outlet pressure (Figure 2)  <b>Control Line Option:</b> Type 627W or 627WH with a stem seal between the body outlet pressure and diaphragm case. Pressure is measured under the diaphragm through the 1/4 NPT downstream control line connection (Figure 2)</p> <p><b>Body Sizes and End Connection Styles</b>  <b>NPT:</b> NPS 3/4, 1, or 2  <b>CL150, CL300, CL600 RF Flanged:</b> NPS 1 or 2 / DN 25 or 50  <b>PN 16/25/40:</b> NPS 1 or 2 / DN 25 or 50</p> <p><b>Maximum Spring and Diaphragm Casing Pressure<sup>(1)</sup></b>          See Table 1</p> <p><b>Body Pressure Shell Rating<sup>(1)</sup></b>  <b>NPT (Steel):</b> 2000 psig / 138 bar  <b>NPT (Ductile Iron):</b> 1000 psig / 68.9 bar  <b>CL600 RF Flanged (Steel):</b> 1500 psig / 103 bar</p> <p><b>Maximum Operating Inlet and Outlet Pressure Ranges<sup>(1)</sup></b>          See Table 2 for pressures by orifice and spring range</p> <p><b>Outlet Pressure Ranges</b>  <b>Type 627W:</b> 10 to 150 psig / 0.69 to 10.3 bar  <b>Type 627WH:</b> 140 to 500 psig / 9.7 to 34.5 bar          See Table 2 for pressures by orifice and spring range</p>	<p><b>Orifice Sizes</b>  <b>Standard:</b> 1/4 or 1/2 in. / 6.4 or 13 mm  <b>Optional:</b> 3/32, 1/8, 3/16, or 3/8 in. / 2.4, 3.2, 4.8, or 9.5 mm          See Table 8</p> <p><b>Temperature Capabilities</b>          See Table 4</p> <p><b>Pressure Registration</b>  <b>Standard:</b> Internal  <b>Optional:</b> External through 1/4 NPT control line connection in the diaphragm case</p> <p><b>Spring Case Vent Connection</b>          3/4 NPT with removable screened vent assembly</p> <p><b>Elastomer Temperature Ranges<sup>(1)</sup></b>          See Table 4</p> <p><b>Control Line Connection</b>          1/4 NPT downstream control line connection</p> <p><b>Wide-Open C<sub>v</sub> and IEC Sizing Coefficients</b>          See Table 5</p> <p><b>Approximate Weight</b>          10 pounds / 5 kg</p> <p><b>Option</b>  <b>Outlet Pressure Gauge (Brass):</b>          0 to 30 psi / 0 to 2.1 bar          0 to 60 psi / 0 to 4.1 bar          0 to 160 psi / 0 to 11.0 bar          0 to 300 psi / 0 to 20.7 bar          0 to 600 psi / 0 to 41.4 bar</p>
--	--

1. The pressure/temperature limits in this Instruction Manual or any applicable standard limitation should not be exceeded.

**Table 1. Maximum Spring and Diaphragm Casing Pressure<sup>(1)</sup>**

MAXIMUM PRESSURE DESCRIPTION	DIAPHRAGM CASING MATERIAL	TYPE 627W		TYPE 627WH	
		psig	bar	psig	bar
Maximum pressure to spring and diaphragm casings to prevent leak to atmosphere (internal parts damage may occur)	Ductile iron	250	17.2	----	----
	Steel or Stainless steel	250	17.2	800	55.2
Maximum pressure to spring and diaphragm casings to prevent burst of casings during abnormal operation (leak to atmosphere and internal parts damage may occur)	Ductile iron	465	32.1	----	----
	Steel or Stainless steel	1500	103	1500	103
Maximum diaphragm casing overpressure (above setpoint) to prevent damage to internal parts	All materials	60	4.1	120	8.3

1. If the spring case is pressurized, a metal adjusting screw cap is required. Contact your local Sales Office for details.

# Types 627W and 627WH

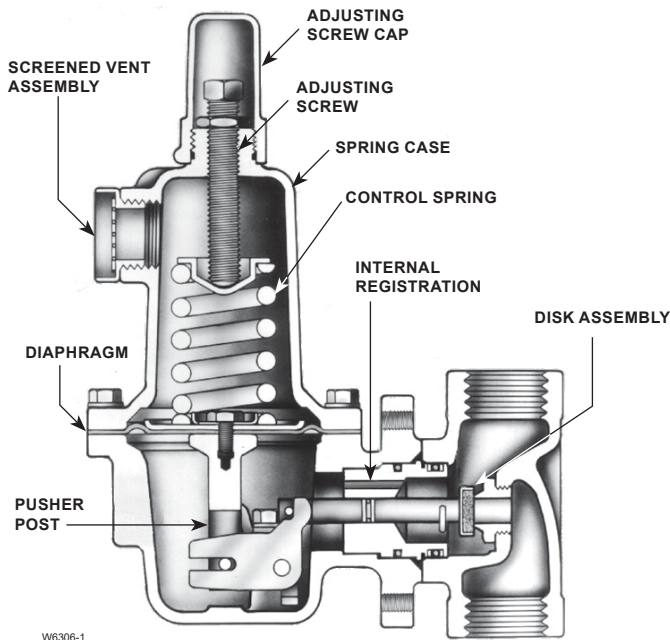

DETAIL OF TYPE 627W WITH INTERNAL DOWNSTREAM PRESSURE REGISTRATION

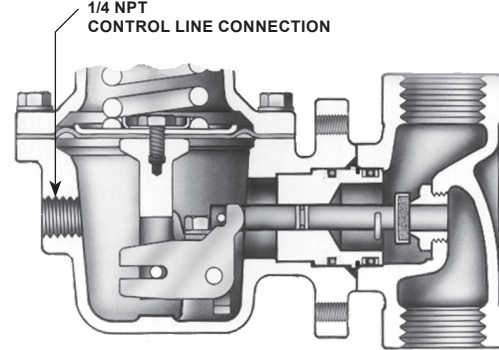

DETAIL OF TYPE 627W WITH EXTERNAL DOWNSTREAM PRESSURE REGISTRATION

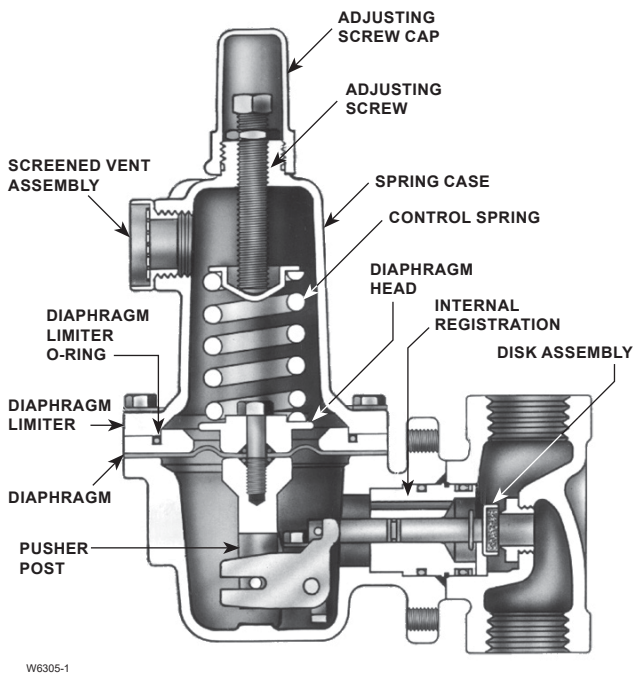

DETAIL OF TYPE 627WH WITH INTERNAL DOWNSTREAM PRESSURE REGISTRATION

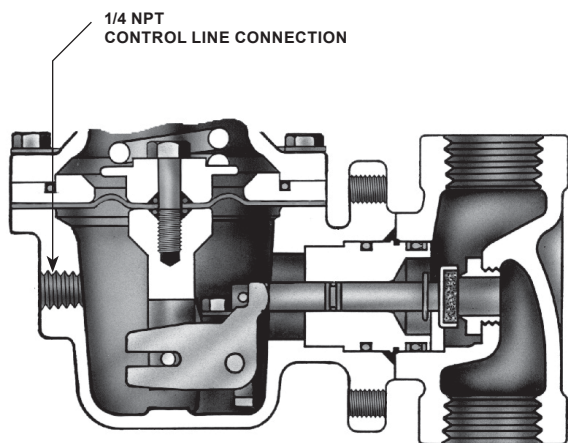

DETAIL OF TYPE 627WH WITH EXTERNAL DOWNSTREAM PRESSURE REGISTRATION AND CONNECTION FOR OUTLET PRESSURE GAUGE

Figure 2. Types 627W and 627WH Construction Details

# Types 627W and 627WH

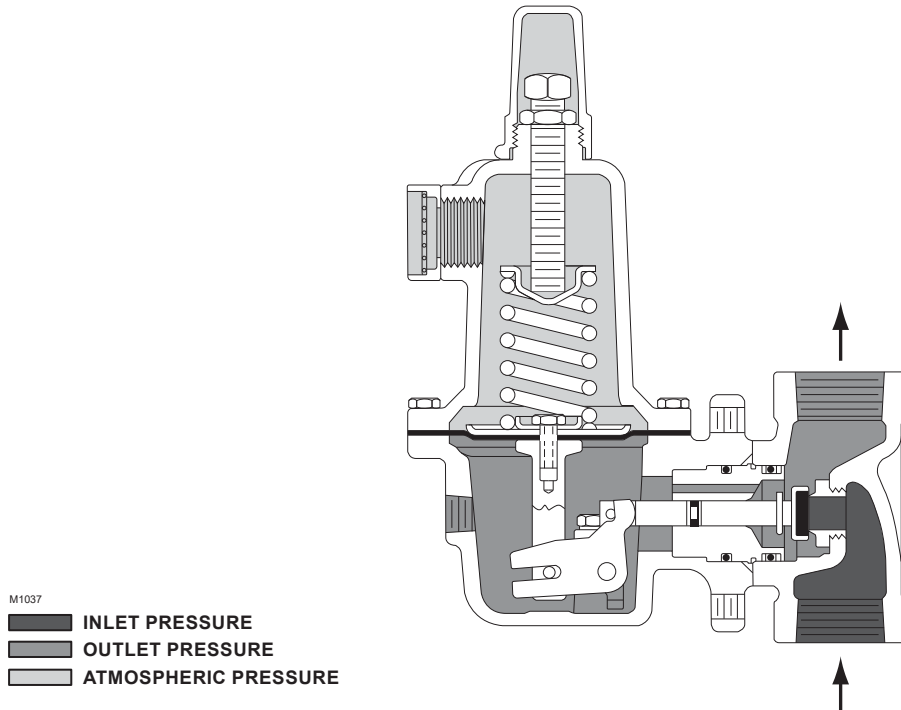

Figure 3. Type 627W Operational Schematic (Also Typical of Type 627WH)

## Principle of Operation

The Type 627W or 627WH (refer to Figure 2) is a direct-operated regulator. On the internal registration version, downstream pressure is registered internally through the body to the under side of the diaphragm. When the downstream pressure is at or above the set pressure, the disk is held against the seat, and there is no flow through the regulator. When demand increases, downstream pressure drops slightly allowing the spring to extend, moving the stem down and the disk away from the seat. This allows flow through the body to the downstream system.

Types 627W and 627WH direct-operated regulators are also available in a downstream control line version. This version has a stem seal between the body outlet pressure and diaphragm case. Pressure is registered under the diaphragm through the 1/4 NPT downstream control line connection (Figure 2).

## Installation

### WARNING

**Personal injury, equipment damage, or leakage due to escaping liquid or bursting of pressure-containing parts may result if this regulator is overpressured or installed where service**

**connection could exceed the limits given in Tables 1, 2, and 4 or where conditions exceed any ratings of the adjacent piping or piping connections.**

**To avoid such injury or damage, provide pressure-relieving or pressure-limiting devices to prevent service conditions from exceeding those limits.**

**Additionally, the control line could be broken off the regulator by physical damage, causing personal injury and property damage due to escaping liquid. To avoid such injury and damage, install the regulators and control line where they are protected from physical damage.**

### CAUTION

**Liquid pressure control systems should be designed using engineering practices to eliminate quick control starting or stopping of the flow stream, which can produce water hammer.**

Regulator operation within ratings does not preclude the possibility of damage from debris in the lines or from external sources. A regulator should be inspected for damage periodically and after any overpressure

# Types 627W and 627WH

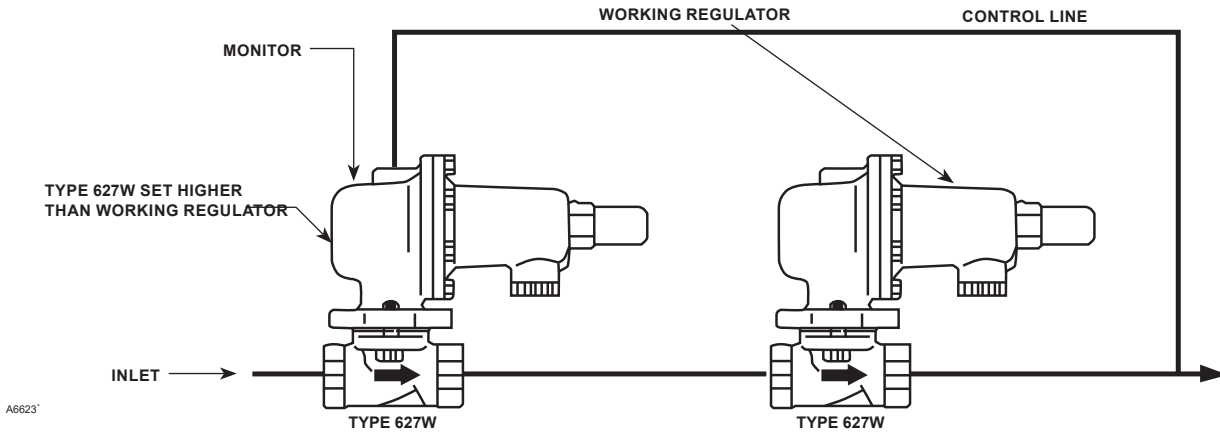

Figure 4. Monitor Regulator Schematic

Table 2. Maximum Inlet Pressure, Differential Pressure, and Outlet Pressure Ranges

Type	OUTLET PRESSURE RANGE, SPRING PART NUMBER, AND COLOR, psig / bar	ORIFICE SIZE		MAXIMUM INLET PRESSURE				MAXIMUM DIFFERENTIAL PRESSURE			
				Elastomer Disk		Nylon Disk		Elastomer Disk		Nylon Disk	
		In.	mm	psig	bar	psig	bar	psid	bar d	psid	bar d
627W	10 to 20 / 0.69 to 1.4 10B3076X012 Yellow	1/4	6.4	220	15.2	420	29.0	200	13.8	400	27.6
		1/2	13	220	15.2	250	17.2	200	13.8	250	17.2
	15 to 40 / 1.0 to 2.8 10B3077X012 Green	1/4	6.4	240	16.5	440	30.3	200	13.8	400	27.6
		1/2	13	240	16.5	300	20.7	200	13.8	300	20.7
	35 to 80 / 2.4 to 5.5 10B3078X012 Blue	1/4	6.4	280	19.3	480	33.1	200	13.8	400	27.6
		1/2	13	280	19.3	480	33.1	200	13.8	400	27.6
627WH	70 to 150 / 4.8 to 10.3 10B3079X012 Red	1/4	6.4	350	24.1	550	37.9	200	13.8	400	27.6
		1/2	13	350	24.1	550	37.9	200	13.8	400	27.6
	140 to 250 / 9.7 to 17.2 10B3078X012 Blue	1/4	6.4	450	31.0	650	44.8	200	13.8	400	27.6
		1/2	13	450	31.0	500	34.5	200	13.8	250	17.2
240 to 500 / 16.5 to 34.5 10B3079X012 Red	1/4	6.4	700	48.3	900	62.1	200	13.8	400	27.6	
	1/2	13	700	48.3	750	51.7	200	13.8	250	17.2	

condition. Key numbers referenced in this section are shown in Figures 5 and 6. Ensure that the operating elastomer temperature ranges listed in Table 4 are not exceeded. Like most regulators, Types 627W and 627WH regulators have outlet pressure ratings that are lower than their inlet pressure ratings.

1. Only personnel qualified through training and experience should install, operate, or maintain this regulator.
2. For a regulator that is shipped separately, make sure that there is no damage to, or foreign material in, the regulator.
3. Ensure that all tubing and piping have been blown free of foreign debris.
4. The regulator may be installed in any position as long as the flow through the body is in the direction indicated by the arrow cast on the body.

5. If continuous operation is required during inspection or maintenance, install a three-valve bypass around the regulator.

## WARNING

**The vent line or stack opening must be protected against condensation or clogging.**

6. Position the body (key 1) and/or diaphragm spring case (key 29) so it will not collect moisture or debris in the screened vent. If the regulator requires repositioning, refer to the Body Area Maintenance Procedures and/or the diaphragm case area maintenance procedures in the Maintenance section to reposition the screened vent for the application.

# Types 627W and 627WH

**Table 3. Outlet Pressure Ranges**

TYPE	SPRING RANGE		COLOR	SPRING PART NUMBER	SPRING FREE LENGTH		SPRING WIRE DIAMETER	
	psig	bar			In.	mm	In.	mm
627W	10 to 20	0.69 to 1.4	Yellow	10B3076X012	3.19	81.0	0.170	4.32
	15 to 40	1.0 to 2.8	Green	10B3077X012	3.19	81.0	0.207	5.26
	35 to 80	2.4 to 5.5	Blue	10B3078X012	3.20	81.3	0.262	6.66
	70 to 150	4.8 to 10.3	Red	10B3079X012	3.07	78.0	0.313	7.95
627WH	140 to 250	9.7 to 17.2	Blue	10B3078X012	3.20	81.3	0.262	6.66
	240 to 500	16.5 to 34.5	Red	10B3079X012	3.07	78.0	0.313	7.95

**Table 4. Elastomer Temperature Ranges**

MATERIAL	DISK/DIAPHRAGM	TEMPERATURE RANGE		USAGE
		°F <sup>(1)</sup>	°C <sup>(1)</sup>	
Nitrile (NBR)	Disk	-40 to 180	-40 to 82	General
	Diaphragm			
Fluorocarbon (FKM)	Disk	0 to 300	-18 to 149	Not Recommended for Hot Water Service
	Diaphragm			
Ethylenepropylene (EPDM)	Disk	-40 to 275	-40 to 135	Not Recommended for Hydrocarbon Service
	Diaphragm			
Perfluoroelastomer (FFKM)	Disk	0 to 400	-18 to 204	Corrosive
Nylon (PA)	Disk	-40 to 200	-40 to 93	General
Polytetrafluoroethylene (PTFE)	Diaphragm Protector	-40 to 400	-40 to 204	Corrosive

1. Stainless steel body is rated to -40°F / -40°C. Steel and ductile iron bodies are rated to -20°F / -29°C.

**Table 5. Flow and Sizing Coefficients**

BODY SIZES		ORIFICE SIZE									
		Wide-Open C <sub>v</sub> for Relief Sizing		K <sub>m</sub>		IEC Sizing Coefficients					
						X <sub>T</sub>		F <sub>D</sub>		F <sub>L</sub>	
NPS	DN	1/4 in. / 6.4 mm	1/2 in. / 13 mm	1/4 in. / 6.4 mm	1/2 in. / 13 mm	1/4 in. / 6.4 mm	1/2 in. / 13 mm	1/4 in. / 6.4 mm	1/2 in. / 13 mm		
3/4		1.63	4.87	0.76	0.74	0.592	0.962	0.50	0.50	0.87	0.86
1	25	1.70	5.29			0.543	0.815				
2	50	1.66	5.01			0.620	1.01				

**Table 6. Maximum Torque Values**

KEY NUMBER <sup>(1)</sup>	DESCRIPTION	FT-LB	N•m
2	Orifice	25	34
3	Cap Screw (with ductile iron or steel diaphragm casing)	25	34
18	Lever, Cap Screw	7	9
37	Spring Case Cap Screw (with ductile iron diaphragm casing)	7	9
	Spring Case Cap Screw (with steel diaphragm casing)	35	47
46	Diaphragm Cap Screw (Type 627W)	7	9
	Diaphragm Cap Screw (Type 627WH)	14	19

1. Refer to Figures 5 and 6 for key numbers.



## Startup

### WARNING

**To avoid personal injury or property damage during startup, release downstream pressure to prevent an overpressure condition on the diaphragm of the regulator. In order to avoid an overpressure condition and possible equipment damage, pressure gauges should always be used to monitor pressure during startup.**

1. Slowly open the upstream shutoff valve.
2. Slowly open the downstream shutoff valve.
3. Check all connections for leaks.
4. Make final control spring adjustments according to the adjustment procedures.

## Adjustment

The range of allowable pressure settings is marked on the nameplate. If a pressure setting beyond this range is necessary, substitute the appropriate regulator control spring. Change the nameplate to indicate the new pressure range.

Before increasing the setting, refer to Tables 1 and 2. Review the pressure limits for the control spring range being used and be certain that the new pressure setting will not result in an overpressure condition.

### Note

**Always use a pressure gauge to monitor pressure when making adjustments.**

Refer to Figures 5 and 6 for key number location.

1. Remove the adjusting screw cap (key 36).
2. Loosen the locknut (key 34).
3. Increase the outlet pressure setting by turning the adjusting screw (key 35) clockwise. Decrease the outlet pressure settings by turning the adjusting screw counterclockwise.

## Shutdown

### WARNING

**To avoid personal injury or property damage or damage to regulator or downstream components during shutdown, release downstream pressure to prevent an overpressure condition on the diaphragm of the regulator.**

1. Close the nearest upstream shutoff valve.
2. Close the nearest downstream shutoff valve.
3. Open the vent between the regulator and the downstream shutoff valve nearest to it.

## Maintenance

Unless otherwise specified the following maintenance procedures apply to all Types 627W and 627WH regulators. For a summary of maximum torque values, refer to Table 6.

Due to normal wear, damage from external sources, or debris in the line, regulator parts such as the valve plug assembly, orifice, and diaphragm must be inspected periodically and replaced as necessary to ensure correct performance.

The frequency of inspection and replacement depends upon the severity of conditions and the requirements of state and federal laws and regulations. Normal wear of the orifice and disk assembly is accelerated with high pressure drops and with large amounts of impurities in the flow stream. Instructions are given below for replacing the valve plug assembly, orifice, diaphragm, and O-rings. These procedures may also be used for disassembly required for inspection and replacement of other parts.

### Body Area Maintenance Procedures

These procedures are for gaining access to the valve plug assembly, orifice, lower casing O-ring and stem assembly. All pressure must be released from the diaphragm casing before the following steps can be performed.

While using the following procedures, refer to Figures 5 and 6 for key number location.

### Replacing the Valve Plug Assembly or Orifice

1. To inspect and replace the valve plug assembly (key 9) or orifice (key 2), remove the cap screws (key 3, not shown), and separate the lower diaphragm casing (key 5) from the body (key 1).
2. Inspect and, if necessary, remove the orifice (key 2). If removed, coat the threads of the replacement orifice with lubricant (key 38) and tighten to 25 ft-lb / 34 N•m.
3. Inspect the valve plug assembly (key 9) and, if necessary, remove the hair pin clip (key 13) that holds the valve plug assembly in place. If replacing the valve plug assembly is the only maintenance required, skip to step 10.

# Types 627W and 627WH

---

## *Replacing the Stem Assembly*

If it is necessary to perform maintenance on the stem assembly, continue with steps 4 through 13.

4. Remove the stem guide (key 8) from the lower diaphragm casing (key 5). Unhook from the lever (key 15) and remove the stem (key 10) from the lower diaphragm casing (key 5).
5. Remove and inspect the stem O-ring (key 11) and replace if necessary. Also inspect and if necessary replace the O-ring (key 44) and backup springs.
6. Remove and inspect the stem backup rings (key 12) and replace if necessary.
7. Apply lubricant to the stem O-ring (key 11).
8. For assembly, insert the stem (key 10) into the lower diaphragm casing (key 5) and hook it on the lever (key 15).
9. Insert parts into the lower diaphragm casing (key 5) that were removed in steps 4 through 6.
10. Install the valve plug assembly (key 9), line up the hole in the valve plug assembly and stem (key 10) and insert the hair pin clip (key 13).
11. Position the diaphragm casing plus attached parts in relation to the body (key 1) so that they are correct for the application.
12. Secure the lower diaphragm casing to the body with the cap screw (key 3). For ductile iron or steel diaphragm casings, tighten the cap screws (key 3) to 25 ft-lb / 34 N•m.
13. It may be necessary to reposition the diaphragm spring case to prevent rain, ice, and foreign debris from entering the spring case. Refer to the Diaphragm and Spring Case Area Maintenance Procedures.

## **Diaphragm and Spring Case Area Maintenance Procedures**

These procedures are for gaining access to the control spring, diaphragm assembly, and lever assembly. All spring pressure must be released from the diaphragm casing before these steps can be performed.

While using the following procedures, refer to Figures 5 and 6 for key number locations.

1. Remove the adjusting screw cap (key 36), loosen the lock nut (key 34), and turn the adjusting screw (key 35) counterclockwise until all compression is removed from the control spring (key 32).

2. Remove the cap screws (key 37), and lift off the spring case (key 29). If changing the spring (key 32) or repositioning the spring case is the only maintenance required, install the replacement spring (key 32) or rotate the spring case so it is correct for the application. Skip to step 13. For diaphragm area maintenance, continue with step 3.
3. Remove the diaphragm limiter (key 50) and O-ring (key 51) on the Type 627WH only. Remove the diaphragm assembly by tilting it so that the pusher post assembly (key 19) slips off the lever (key 15).
4. If it is necessary to replace the lever assembly (key 15), remove the lever cap screws (key 18).
5. Install the replacement lever (key 15) into the lever retainer (key 16) by inserting the lever pin (key 17). Secure the lever assembly (key 15) into the lower diaphragm casing (key 5) with the cap screws (key 18) and tighten the cap screw to 7 ft-lb / 9 N•m.

If it is necessary to perform maintenance on the diaphragm assembly continue with steps 6 through 10 and step 17, otherwise skip to step 11.

6. Remove cap screw (key 46), lower spring seat (key 31 for Type 627W only, Figure 5) and diaphragm head (key 24). On the Type 627WH remove O-ring (key 52, Figure 6). Separate the diaphragm (key 23) from the pusher post (key 19).
7. Install the diaphragm (key 23), in reverse order of step 6. On the pusher post (key 19), insert and finger tighten the cap screw (key 46).
8. Hook the pusher post (key 19) on the lever (key 15), then turn the diaphragm (key 23) to match the holes in the diaphragm with the holes in the lower diaphragm casing (key 5).
9. Unhook the pusher post (key 19) from the lever (key 15) and tighten the cap screw (key 46) to 7 ft-lb / 9 N•m.
10. Hook the pusher post (key 19) on the lever (key 15) and check the hole alignment. If necessary, loosen the cap screw (key 46) and reposition the diaphragm (key 23) on the pusher post (key 19). Tighten the cap screw to 7 ft-lb / 9 N•m.
11. Insert the diaphragm assembly into the lower diaphragm casing (key 5).
12. Install the spring (key 32) and upper spring seat (key 33), and apply lubricant to the upper spring seat.



# Types 627W and 627WH

13. Install the spring case (key 29) so that the vent (key 30) is in the correct position for the application. Insert the cap screws (key 37) and finger tighten.
14. Screw in the adjustment screw (key 35) to put slack into the diaphragm (key 23).
15. Using a crisscross pattern, tighten the cap screw (key 37) to 7 ft-lb / 9 N•m.
16. If necessary, refer to the installation and/or the startup and adjustment procedures.
17. Install the adjusting screw cap (key 36) after regulator adjustment.

## Parts Ordering

When corresponding with your local Sales Office about this equipment, always reference the information found on the regulator nameplate.

When ordering replacement parts, reference the complete 11-character part number of each needed part as found in the following parts list.

## Parts List

Key	Description	Part Number
1	Body	(See Table 7)
2*	Orifice	(See Table 8)
3	Cap Screw (2 required, Not shown) Ductile iron or steel spring case and diaphragm casing (plated steel cap screw)	1A560724052
	Stainless steel spring case and diaphragm casing (SST cap screw)	1A5607X0052
5	Lower Diaphragm Casing	
	Type 627W	
	Ductile iron	30B3053X012
	WCC Steel	30B3104X012
	CF8M Stainless steel	30B3104X082
	Type 627W with control line or 1/4 NPT Tap	
	Ductile iron	39A5987X012
	WCC Steel	30B8734X012
	CF8M Stainless steel	30B8734X032
	Type 627WH	
	WCC Steel	30B3104X012
	CF8M Stainless steel	30B3104X082
	Type 627WH with control line or 1/4 NPT Tap	
	WCC Steel	30B8734X012
	CF8M Stainless steel	30B8734X032
8	Stem Guide, 316 Stainless steel	
	Standard	14B7259X012
	With control line	10B3085X012

Key	Description	Part Number
9*	Valve Plug Assembly	
	Stainless steel/Nitrile (NBR)	1C4248X0202
	Stainless steel/Nylon (PA)	1C4248X0062
	Stainless steel/Fluorocarbon (FKM)	1C4248X0052
	Stainless steel/Ethylenepropylene (EPDM)	1C4248X0302
	Stainless steel/Perfluoroelastomer (FFKM)	1C4248X0392
10	Stem, 416 Stainless steel	10B3059X012
11*	Stem O-ring (material same as diaphragm)	
	Nitrile (NBR)	1D687506992
	Fluorocarbon (FKM)	1N430406382
	Ethylenepropylene (EPDM)	1D6875X0032
	Perfluoroelastomer (FFKM) (with Diaphragm Protector)	1D6875X0082
12*	Stem Backup Ring, Polytetrafluoroethylene (PTFE) (2 required)	1K786806992
13	Hair Pin Clip, Stainless steel	10B3058X012
14	Drive Pin, Stainless steel	1H3671X0012
15	Lever, 304 Stainless steel	20B3063X022
16	Lever Retainer, Stainless steel	34B6659X012
17	Lever Pin, Stainless steel	10B3083X022
18	Cap Screw, 18-8 Stainless steel (2 required)	1B2905X0012
19	Pusher Post Assembly, Stainless steel	10B3098X032
23*	Diaphragm	
	Type 627W with Ductile iron spring case and diaphragm casing	
	Nitrile (NBR)	10B3069X012
	Fluorocarbon (FKM)	10B3069X032
	Ethylenepropylene (EPDM)	10B3069X042
	Type 627W with WCC steel or CF8M Stainless steel spring case and diaphragm casing	
	Nitrile (NBR)	12B0178X012
	Fluorocarbon (FKM)	12B0178X022
	Ethylenepropylene (EPDM)	12B0178X042
	Type 627WH use with WCC steel or CF8M Stainless steel spring case and diaphragm casing	
	Nitrile (NBR)	12B0178X012
	Fluorocarbon (FKM) (2 required)	12B0178X022
	Ethylenepropylene (EPDM) (2 required)	12B0178X042
24	Diaphragm Head	
	Type 627W, Zinc-plated steel	14B5728X012
	Type 627WH, Stainless steel	12B0175X012
29	Spring Case	
	Ductile iron (Type 627W only)	30B3055X012
	WCC Steel	30B3102X012
	CF8M Stainless steel	30B3102X092
30	Vent Assembly	10B3093X012
31	Lower Spring Seat, Zinc-plated steel	
	Type 627W only	T1142524152
32	Spring, Plated steel	
	Type 627W	
	10 to 20 psig / 0.7 to 1.4 bar, Yellow	10B3076X012
	15 to 40 psig / 1.0 to 2.8 bar, Green	10B3077X012
	35 to 80 psig / 2.4 to 5.5 bar, Blue	10B3078X012
	70 to 150 psig / 4.8 to 10.3 bar, Red	10B3079X012
	Type 627WH	
	140 to 250 psig / 9.65 to 17.2 bar, Blue	10B3078X012
	240 to 500 psig / 16.5 to 34.5 bar, Red	10B3079X012

\*Recommended spare part

# Types 627W and 627WH

**Table 7. Body (Key 1)**

END CONNECTION STYLE	BODY MATERIAL	NPS 3/4	NPS 1 / DN 25	NPS 2 / DN 50
NPT	Ductile Iron (Type 627W only)	30B3046X012	30B3048X012	30B3096X012
	WCC Steel	30B3050X012	30B3051X012	30B7452X012
	CF8M Stainless Steel	30B3050X062	30B3051X092	30B7452X052
CI150 RF	WCC Steel	----	43B8656X022	44B0666X012
	CF8M Stainless Steel	----	43B8656X052	44B0666X022
CL300 RF	WCC Steel	----	41B8978X012	41B8080X012
	CF8M Stainless Steel	----	41B8978X072	41B8080X072
CL600 RF	WCC Steel	----	40B6754X012	40B6756X012
	CF8M Stainless Steel	----	40B6754X102	40B6756X062
PN 16/25/40	WCC Steel	----	44B0386X012	44B3342X012
	CF8M Stainless Steel	----	44B0386X032	44B3342X032

**Table 8. Orifice (Key 2)**

ORIFICE DIAMETER		PART NUMBER	
In.	mm	303 Stainless Steel	316 Stainless Steel
3/32	2.4	0R044135032	0R0441X0012
1/8	3.2	1A936735032	1A9367X0022
3/16	4.8	00991235032	009912X0012
1/4	6.4	0B042035032	0B0420X0012
3/8	9.5	0B042235032	0B0422X0012
1/2	13	1A928835032	1A9288X0012

Key	Description	Part Number	Key	Description	Part Number
33	Upper Spring Seat, Zinc-plated steel	1D667125072	51*	O-ring	
34	Locknut, Zinc-plated steel	1D667728982		Type 627WH only	
35	Adjusting Screw, Plated steel	10B3081X012		Nitrile (NBR)	ERAA19160A5
36	Adjusting Screw Cap, Plastic	20B3082X012		Fluorocarbon (FKM)	ERAA19160A3
37	Cap Screw, Plated steel (8 required)			Ethylenepropylene (EPDM)	ERAA19160A1
	Type 627W			Perfluoroelastomer (FFKM)	
	Ductile iron casings	1A391724052		(with Diaphragm protector)	ERAA19160A4
	WCC Steel casings	1A368324052	52*	O-ring (material same as diaphragm)	
	CF8M Stainless steel casings (SST cap screw)	1A6751X0092		Type 627W (1 required, not shown)	
	Type 627WH			Nitrile (NBR)	1C853806992
	WCC Steel casings	1A346424052		Fluorocarbon (FKM)	1C8538X0052
	CF8M Stainless steel casings (SST cap screw)	1A3464X0022		Ethylenepropylene (EPDM)	1C8538X0072
44*	O-ring, Material same as diaphragm (2 required)			Perfluoroelastomer (FFKM)	
	Nitrile (NBR)	ERAA19159A0		(with Diaphragm protector)	1C8538X0072
	Fluorocarbon (FKM)	ERAA19159A1		Type 627WH (2 required)	
	Ethylenepropylene (EPDM)	ERAA19159A2		Nitrile (NBR)	1C853806992
	Perfluoroelastomer (FFKM)			Fluorocarbon (FKM)	1C8538X0052
	(with Diaphragm protector)	ERAA19159A3		Ethylenepropylene (EPDM)	1C8538X0072
				Perfluoroelastomer (FFKM)	1C8538X0072
45*	Backup Ring,		67	Drive Screw (2 required, Not shown)	1A368228982
	PTFE (2 required)	10B3106X012	68*	Diaphragm Protector (Not shown)	
46	Cap Screw, Zinc-plated steel			Ductile iron casing	14B3636X012
	Type 627W	1A381624052		Steel or stainless steel	14B4324X012
	Type 627WH	1C379124052	72	Pipe Plug for 1/4 NPT Tap (Not shown)	
50	Diaphragm Limiter, Zinc-plated steel			Zinc-plated steel	1A767524662
	Type 627WH only	22B0176X012		Stainless steel	1A767535072

\*Recommended spare part

# Types 627W and 627WH

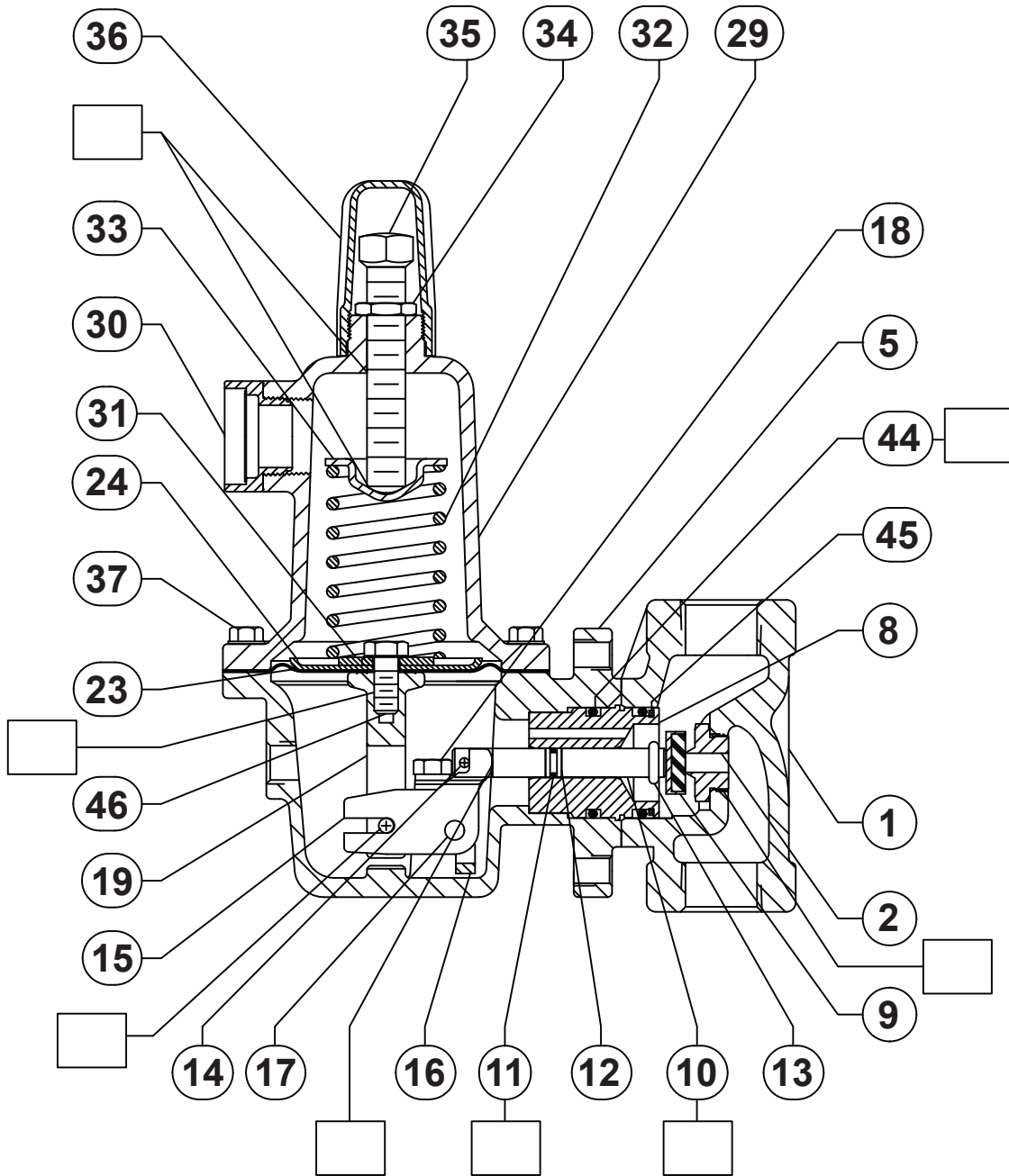

34B7395

□ APPLY LUBRICANT  
PARTS NOT SHOWN: 3

Figure 5. Type 627W Regulator Assembly

# Types 627W and 627WH

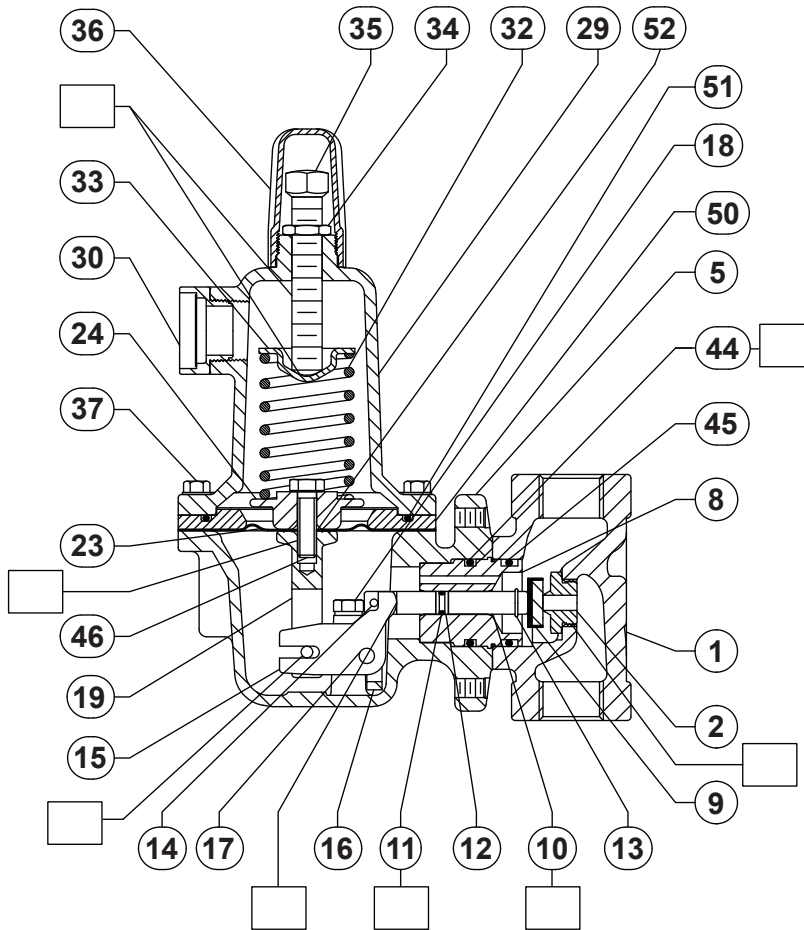

37B9752

□ APPLY LUBRICANT  
PARTS NOT SHOWN: 3

Figure 6. Type 627WH Regulator Assembly

✉ Webadmin.Regulators@emerson.com

🔍 Fisher.com

📘 Facebook.com/EmersonAutomationSolutions

🌐 LinkedIn.com/company/emerson-automation-solutions

🐦 Twitter.com/emr\_automation

## Emerson Automation Solutions

### Americas

McKinney, Texas 75070 USA  
T +1 800 558 5853  
+1 972 548 3574

### Europe

Bologna 40013, Italy  
T +39 051 419 0611

### Asia Pacific

Singapore 128461, Singapore  
T +65 6777 8211

### Middle East and Africa

Dubai, United Arab Emirates  
T +971 4 811 8100

D102504X012 © 1998, 2020 Emerson Process Management Regulator Technologies, Inc. All rights reserved. 03/20.  
The Emerson logo is a trademark and service mark of Emerson Electric Co. All other marks are the property of their prospective owners. Fisher™ is a mark owned by Fisher Controls International LLC, a business of Emerson Automation Solutions.

The contents of this publication are presented for informational purposes only, and while every effort has been made to ensure their accuracy, they are not to be construed as warranties or guarantees, express or implied, regarding the products or services described herein or their use or applicability. All sales are governed by our terms and conditions, which are available upon request. We reserve the right to modify or improve the designs or specifications of such products at any time without notice.

Emerson Process Management Regulator Technologies, Inc does not assume responsibility for the selection, use or maintenance of any product. Responsibility for proper selection, use and maintenance of any Emerson Process Management Regulator Technologies, Inc. product remains solely with the purchaser.

